

BACK

DESIGN GUIDE

5TH EDITION

FORMEX™

FORMEX™ GK

STATEX™

FLAME RETARDANT
POLYPROPYLENE INSULATION

TWFormex®

TABLE OF CONTENTS

• Introduction and Overview	1
• Die Cutting/Types of Presses	2
• Types of Dies	2
• Steel Rule Dies	3
• Design for Die Cutting	3
Blanks	4
Scores	4
Holes	5
Tabs	5
• Part Processing	6
Marking	6
Lamination	6
EMI/RFI Shielding	6
Thermoforming	7
Heavy Gauge Fabrication	7
Joinery	7
• Joinery Examples	8-9
• UL Information	10-11
• FORMEX Product Information	12-13
• FORMEX GK Product Information	14
• STATEX Product Information	15
• Sample Assembly Instructions	16
• Sample	17

The goal of this design guide is to provide useful and practical information to engineers, designers, and technical staff specifying insulators

and other die cut parts from

FORMEX/FORMEX GK/ STATEX

material(s). General process information

and specific design suggestions help improve

functionality, quality and durability of the product. This booklet is

intended to provide guidance and not establish definitive rules.

Please consult your fabricator or die cutter regarding

the specifics of any design.

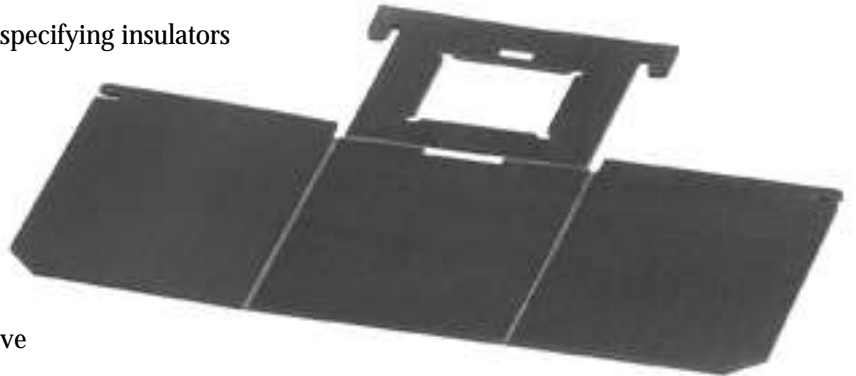

OVERVIEW

FORMEX and FORMEX GK are flame retardant

grades of polypropylene, extruded into sheet and primarily

used for their electrical insulation properties. These materials

meet the insulation requirements for most applications due to their high

dielectric strength (1460 V/mil @ 17 mil thick), low moisture absorption

(<0.1%) and UL 94V-0 flame class rating. Polypropylene provides

exceptional scoring and bending characteristics resulting in superior

folded parts. STATEX, a similar product, has the same basic properties

with the addition of a proprietary surface treatment for static dissipation.

For the purposes of this guide all Formex Products; FORMEX,

FORMEX GK and STATEX can be processed identically.

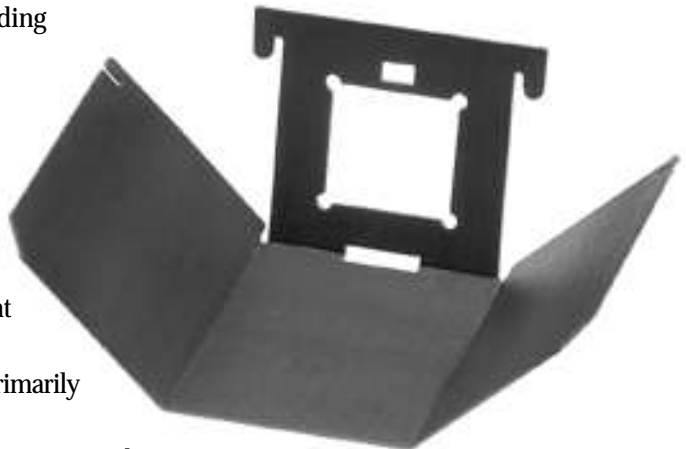

Die cutting is the transfer of pressure through hardened steel dies to softer material in order to cut, score or crease the material into desired shapes or patterns. The most common variables in this process are the press type and die type. The part fabricator's selection is based on equipment availability, material properties, thickness, part geometry, tolerance and required volume, as well as personal experience.

TYPES OF PRESSES

There are three main press types for die cutting use, each having its own advantages. Presses can be automatic or manually operated, use roll or sheet stock, and can handle several types of die cutting tools. Part size, scoring accuracy and processing speed will vary with the type of equipment, however most parts can be processed on any of these machines. Some parts lend themselves to a particular press type due to part size, tolerance, run volumes, die types, etc.

CLICKER PRESS

Operator feeds material, places die and triggers press. Can accommodate forged, engraved or steel rule dies. A nylon lower platen compensates the limited leveling capability of the press. Material may be cut from roll or sheet stock.

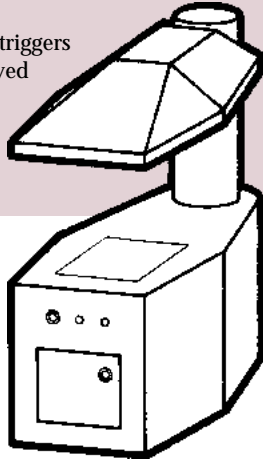

CLAMSHELL PRESS

Automatically operated with manually fed material. Good leveling capability allows a steel lower platen to be used with steel rule dies. Can handle large parts, requires sheet stock and is used for larger volume processing.

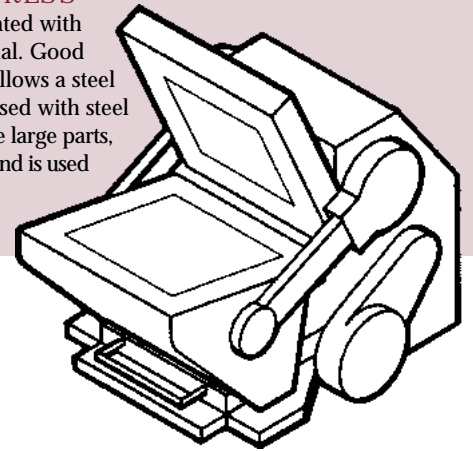

AUTOMATIC PRESS

Operator not always required; feeds and cycles automatically. Cuts steel to steel for good depth accuracy. Primarily uses roll stock, good for high volume runs, can count and prepackage parts.

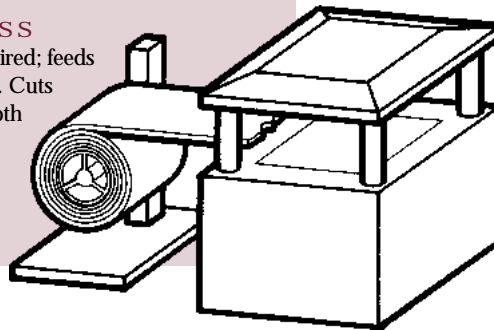

TYPES OF DIES

STEEL RULE DIES

The steel rule die is the most common due to its versatility. Steel rule dies can be used on most presses, can be hand-placed or platen-mounted and are the most economical. (See page 3)

ENGRAVED DIES

Made from a steel block with material etched away to form cutting edges. They are moderately priced, can hold close tolerances and are capable of unique shapes.

FORGED DIES

Made from a tapered steel band, sharpened at the edge which is cut, shaped, and welded into position. They are also moderately priced, capable of close tolerances and are uniquely suited to thicker stock.

MALE/FEMALE DIES

Similar to metal stamping dies. Capable of producing close tolerance features and intricate part designs. Male/female dies are usually used in high volume applications where their cost is justified.

A steel rule die consists of a hardwood base with sharpened steel blades, or rule inserted and connected in a pattern. Different techniques of assembling the punches, blades, ejection, and other die components may be used to accommodate the various characteristics required for each part. Designs which take into consideration the strengths and weaknesses of this die system produce failure-free parts economically.

Steel rule serves two functions; to cut material completely through or to score the material for folding. Center and side bevel rule is used for full or partial cutting. Creasing rule is used to provide a score line without cutting material. The perforating rule is used for “perf” scoring, which is preferred in certain applications. Die construction details are usually specified by the die maker and the part fabricator. Multiple cavity dies are available for higher volume production.

HARDWOOD BASE

Multiple layers of birch or maple provide a tough, shock absorbent, warp resistant base. Grooves cut into the base accept steel rule which is either straight length or hand-bent.

PUNCHES

Inserted into base to form internal cutouts. Available in standard shapes and sizes (round, square or oval) and custom shapes and sizes.

LOWER RULE

Set slightly lower than cutting rule. Used to score or crease material for folding.

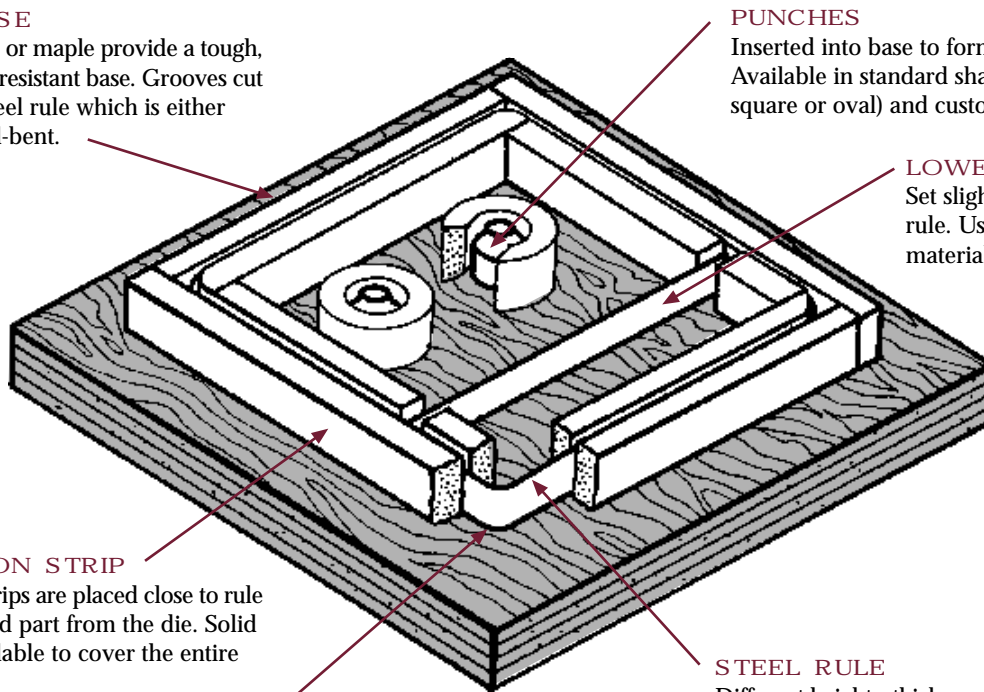

RUBBER EJECTION STRIP

Self-adhesive rubber strips are placed close to rule to help remove finished part from the die. Solid rubber ejection is available to cover the entire cavity, if required.

RADIUS CORNER

Formed by bending a single rule; radius can vary.

STEEL RULE

Different heights, thicknesses and edge treatments provide all linear cutting and scoring/creasing. Rule used to completely cut out any part of the material are set to one height.

DESIGN FOR DIE CUTTING

Die cut parts have four basic elements: blanks, scores, holes and tabs. These features can usually be formed simultaneously.

Optimal part design for die cutting involves a balance between specific features and manufacturing economies.

Design parameters take into consideration the following:

- Lower tool costs and lead times through the use of standard rule and punch components
- Unnecessary features/detail which reduce throughput
- Inappropriate tolerance levels
- Ease of manufacturing.

Blanks are formed by a full depth rule cut which separates the part (blank) from the remaining stock.

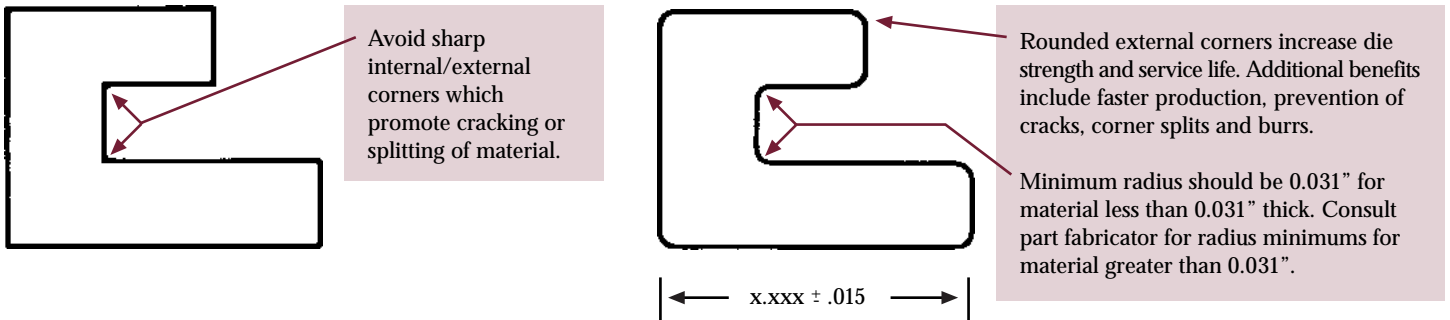

Note: General tolerance shown. Consult your fabricator for more detailed information.

SCORES

Scores are formed by cutting or creasing the blank. This establishes a line along which the part can be easily and accurately folded.

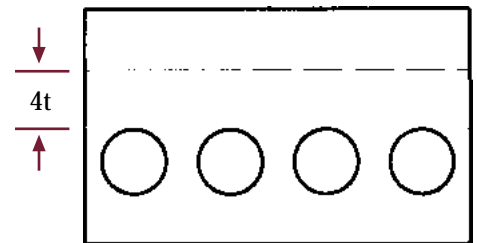
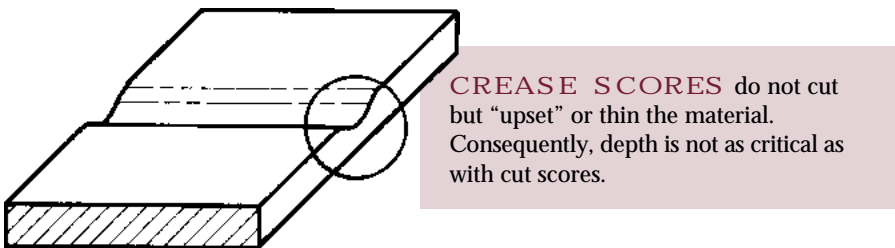
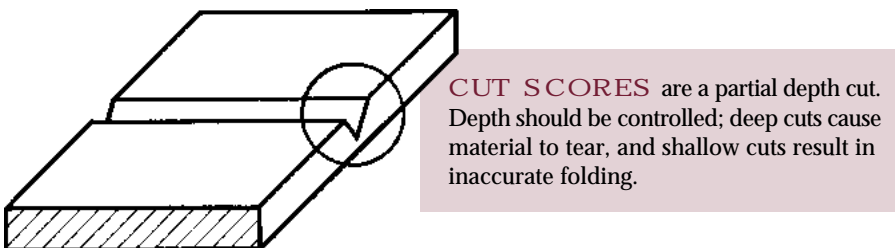

A series of holes must be kept at a minimum distance from a score line to prevent the part from folding through the holes. Four material thicknesses is the recommended minimum.

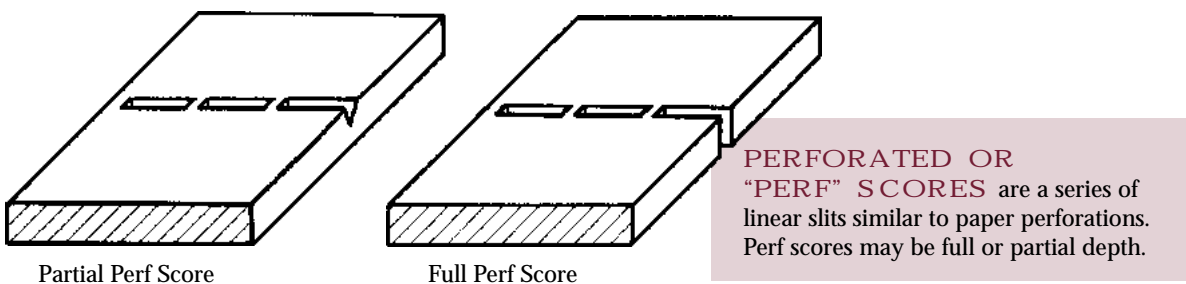

Holes can be produced in the blank in virtually any shape through the use of standard and special punches and rule formed to the desired shape.

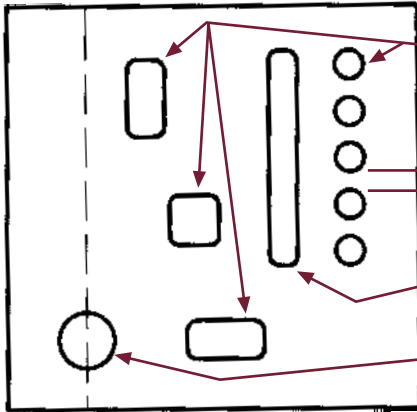

Standard size round punches increase in diameter by 0.015" increments. Use standard punches when possible. Standard square punches are also available.

Use at least two material thicknesses between adjacent holes.

Use an oblong hole to replace a series of holes where possible.

Avoid placing holes on score line.

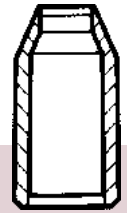

Some punches, predominately the self-ejecting type, have larger diameter bases than the holes they produce. Check with part fabricator to determine the minimum distance between centers.

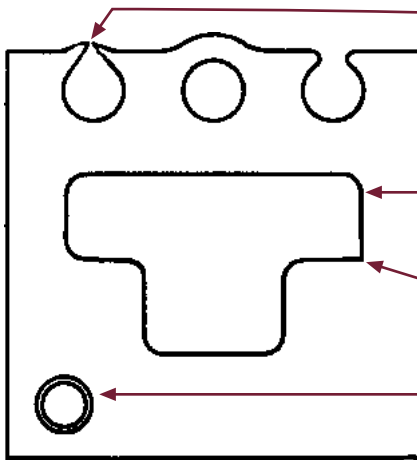

Locate a hole at least two material thicknesses from the edge in order to avoid tearing or bulging during fabrication and handling. Note alternate methods.

Odd shapes can be made by bending a steel rule to the desired shape. Minimum specified radius should be 0.031".

Avoid sharp internal corners which promote material cracking and splitting.

Slugs can be left in if necessary. Indicate to fabricator if slugs are to remain or if part is to be "clean".

TABS

Part design may include tabs for various reasons. Often they are to accommodate an attachment feature. Internal tabs are completely enclosed within the part; external tabs are located along an outside edge.

When putting holes in tabs, provide a minimum of two material thicknesses around the holes.

Provide a slot completely around the tab, if possible.

Tab cuts should not be terminated with bare rule end. The resulting stress riser can cause cracking or tearing.

Internal tabs should be terminated with holes to dissipate stress.

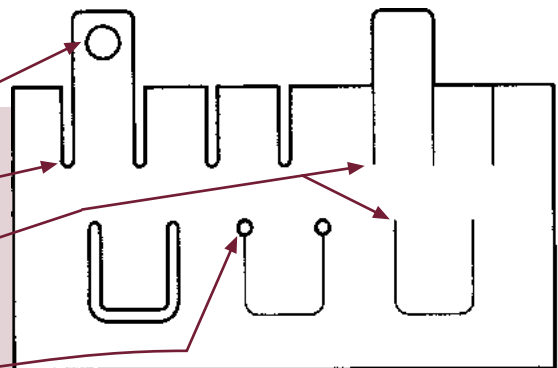

MARKING

Die cut parts may need to be marked for product identification, coding or to provide safety related and/or technical information. Simple requirements such as a part or code numbers may be embossed during die cutting or hand-stamped later. More extensive information may require some form of printing, such as one of the following:

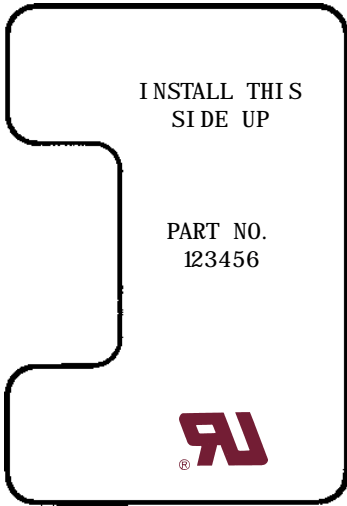

Note: Formex /Formex GK materials have been specifically produced to accept printing inks. If product has become dirty during fabrication, printing quality can be maintained by cleaning the part with pure isopropyl alcohol prior to printing.

LAMINATION

Additional properties can be obtained by laminating other materials to Formex/Formex GK. An example of this is the lamination of aluminum or copper foil to provide EMI/RFI shielding. Lamination with a pressure sensitive adhesive is the most common way of producing a multilayered part. The best results will be achieved by using a soft or cross-linked acrylic adhesive. Acrylic adhesives are commonly used due to their proven long-term holding power and resistance to cold flow and outgassing.

A variety of adhesive tapes are available for specific applications such as laminating, mounting and positioning. Foam-backed tapes can be used where mounting surfaces are uneven.

EMI/RFI SHIELDING

Shielding against electromagnetic and radio frequency interference (EMI/RFI) may be accomplished using a Formex or Formex GK/metal foil laminate. This lamination provides the unique combination of a superior insulator coupled with an EMI/RFI shield. While Formex products may be laminated to different metal foils,

HOT STAMPING

A pigmented transfer film is pressed against the part using a heated platen which transfers the pigment to the part.

SILK SCREENING

Ink is pressed through a selectively-coated screen of fine fabric onto the part. Durability is enhanced by using ink specifically formulated for polypropylene.

PAD PRINTING

Ink is transferred to the part from an etched platen via a silicone pad. Epoxy inks are recommended for sharpness and quality.

FLEXOGRAPHIC PRINTING

A high-speed ink transfer method typically used in high volume printing applications where material is printed prior to die cutting.

EMBOSSED PRINTING

Standard marking punches used to impress identification marks into the material during die cutting is most economical. Custom punches can be fashioned for special characters or symbols.

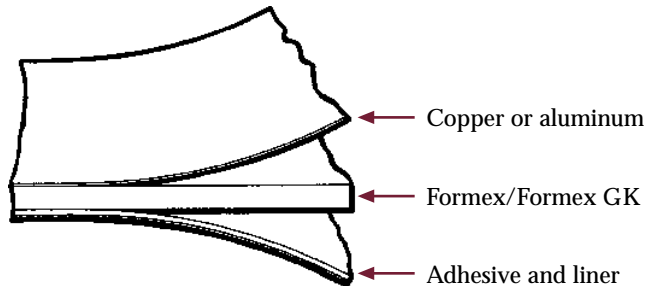

Note: Formex/Formex GK materials have been specifically produced to accept adhesives. Adhesive performance will be improved by maintaining surface cleanliness. Pure isopropyl alcohol may be used for this purpose if required.

2.0 mil dead soft aluminum and copper are economic and widely available. Shielding effectiveness of any system is a function of many different variables. Most applications use aluminum or copper which are proven performers. Ferrous based foils have found acceptance in low frequency magnetic shielding applications.

THERMOFORMING

Thermoforming produces three dimensional parts without scoring and folding. It is accomplished by applying sufficient heat to the material for subsequent drawing over a male die or into a female die.

Best results are obtained by using slow even heating. A preheat cycle prior to final heating is recommended.

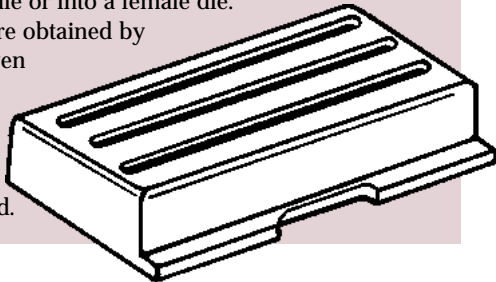

WELDING

Thermal bonding involves bringing the material to its melt temperature, fusing the pieces together and cooling. Heating may be achieved using hot air, resistance heaters, or friction as in the case of ultrasonic welding. Benefits of heat bonding include extremely strong joints as well as self-contained fastening.

HEAVY GAUGE FABRICATION

Heavy gauge material is often formed using a sheet metal brake or forming mixture. The material may be fabricated cold or with the assistance of heat. Strip heaters are used to concentrate heat on the portion of the blank being formed. The blank may also be heated in its entirety prior to forming in a fixture.

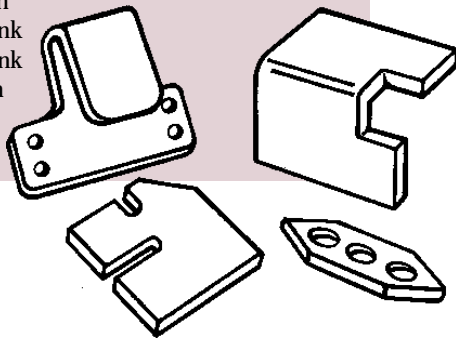

PROTOTYPING

Many times prototype parts or small quantities of pilot run parts are required during the early stages of a project. The use of laser or water jet cutting provides very accurate parts in a fraction of the time required for conventional prototyping. Fabricators can often have prototype parts available within the same day they were requested, particularly when electronic part files are utilized.

JOINERY

Several methods for fastening and joining exist which facilitate assembly. The following pages illustrate examples.

SELF-CONTAINED

Self-contained fasteners are integral to the design of the part and require no external devices. Economic benefits are achieved by eliminating stock, handling and assembly costs.



Rivet

Stalok

Canoe Clip

EXTERNAL FASTENERS

External fasteners may be required when design parameters prevent self-contained fastening. These fasteners need not be limited to conventional screws and nuts. A wide variety of products are available which will provide the secure attachment of the part in its application.

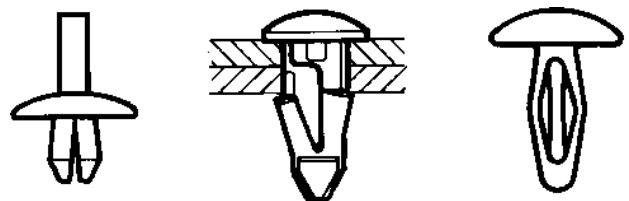

Simple tabs can be used to hold a part in shape during installation. A chassis or enclosure may hold the part after assembly.

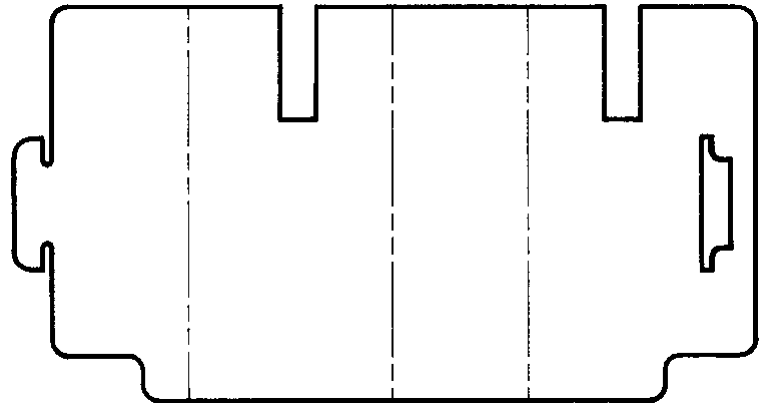
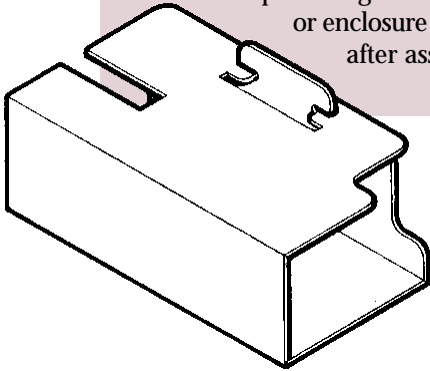

These interlocking corners rely on material flexibility and memory.

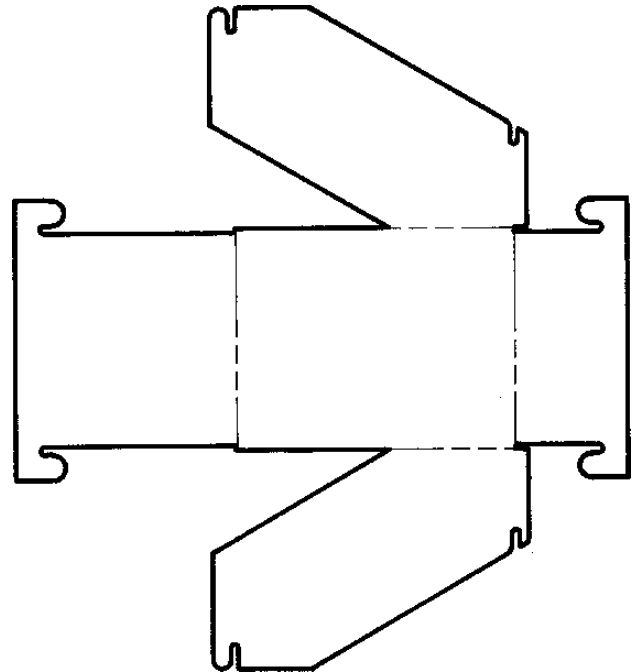
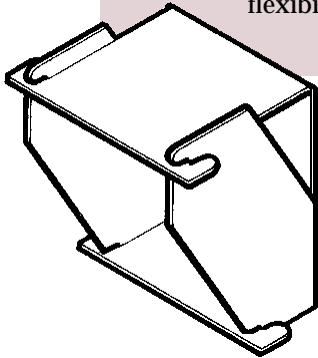

Loose fitting parts can adapt to assemblies with high stack tolerances allowing manufacturing flexibility.

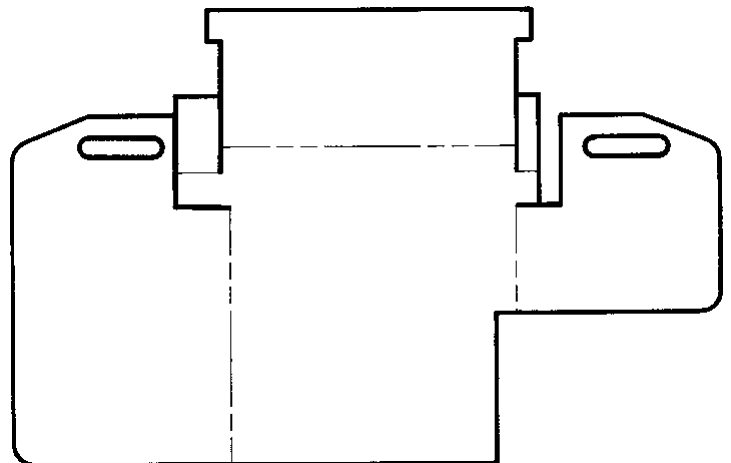
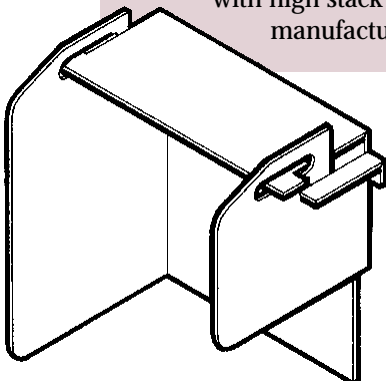

Simple tabs allow parts to be assembled and disassembled if necessary. Heat staking or ultrasonic welding these tabs provides a permanent joint.

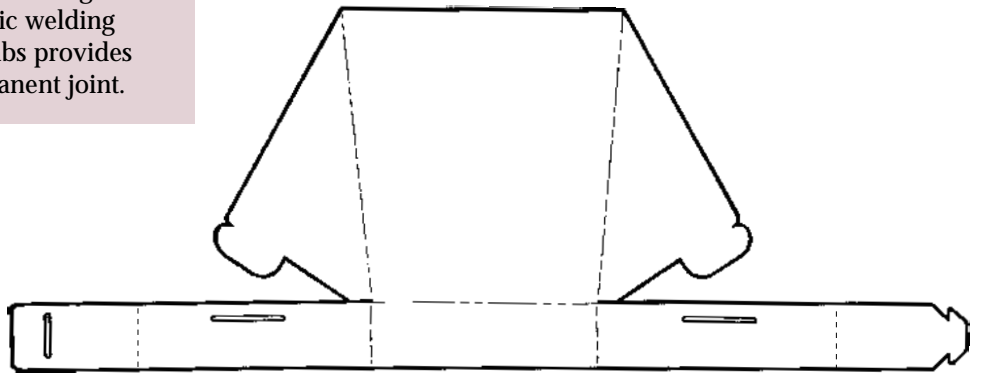
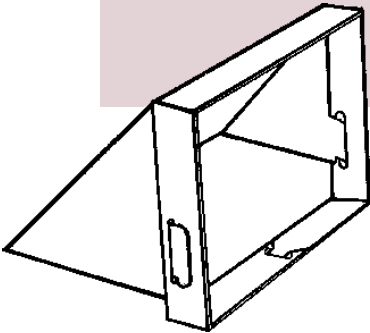

Tabs may be twisted to upset the material or heat staked to provide a permanent installation. When used on PC board applications these tabs require little "real estate".

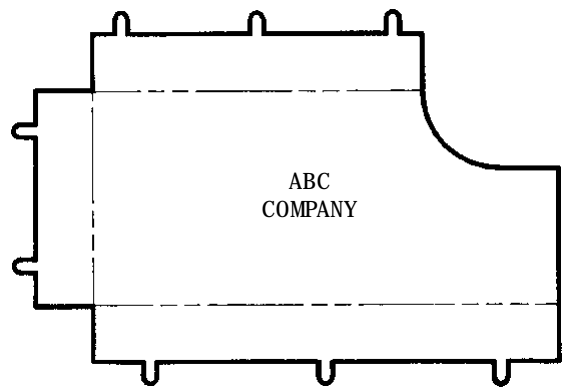
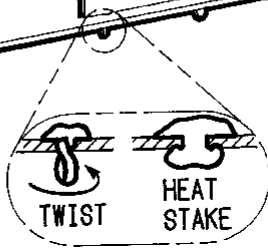
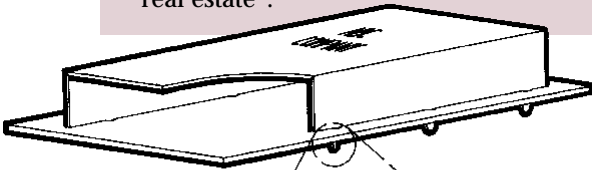

External fasteners can be used to hold the part together as shown or to retain the part in its application.

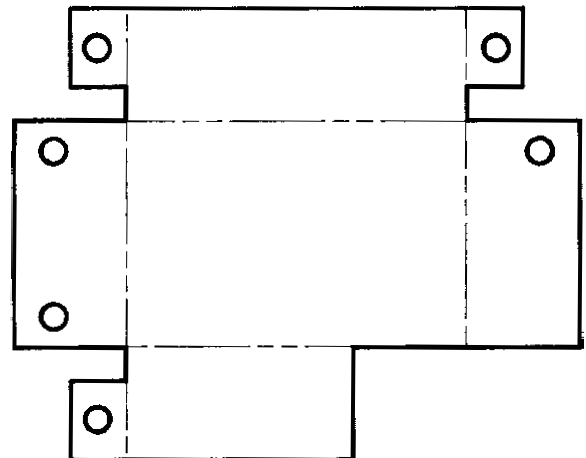
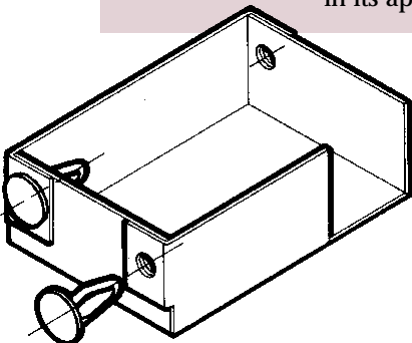

FORMEX™

QMFZ2 Component - Plastics FEBRUARY 25, 2002 E121855

FORMEX, DIV OF ILLINOIS TOOL WORKS INC
1701 W. ARMITAGE COURT ADDISON, IL 60101

Material Designation: FORMEX-(a)(b)(f2)
Product Description: Polypropylene (PP), furnished as sheets.

Color	Min. Thick. mm	Flame class	HWI	HAI	RTI Elec	RTI Imp	RTI Str	IEC GWIT	IEC GWFI
NC	0.20	VTM-0	5	1	95	-	95	-	-
NC, BK	0.41	V-0	4	3	100	90	100	-	-
ALL	0.75	V-0	3	0	110	105	110	-	-
	2.4	V-0	2	0	110	105	110	-	-
	3.0	V-0	2	0	110	115	120	-	-

CTI: 0 HVTR: 0 D495: 6 IEC BP: -

(a) - One to three digit suffix indicating nominal thickness in mils.
(b) - May have an additional letter suffix indicating color.
(f2) - Subjected to one or more of the following tests: Ultraviolet Light, Water Exposure or Immersion in accordance with UL 746C, where the acceptability for outdoor use is to be determined by UL Inc.

Report Date: 05/10/1990 Underwriters Laboratories Inc ® 357863001
UL 94 small-scale test data does not pertain to building materials, furnishings and related contents. UL94 small-scale test data is intended solely for determining the flammability of plastic materials used in components and parts of end-product devices and appliances, where the acceptability of the combination is determined by ULL.

FORMEX™ GK

QMFZ2 Component - Plastics FEBRUARY 25, 2002 E121855

FORMEX, DIV OF ILLINOIS TOOL WORKS INC
1701 W. ARMITAGE COURT ADDISON, IL 60101

Material Designation: FORMEX GK-(a)(b)(f2)
Product Description: Polypropylene (PP), furnished as sheets.

Color	Min. Thick. mm	Flame class	HWI	HAI	RTI Elec	RTI Imp	RTI Str	IEC GWIT	IEC GWFI
ALL	0.05	VTM-0	4	0	115	-	115	-	-
	0.10	VTM-0	4	0	115	-	115	-	-
	0.20	VTM-0	4	0	115	-	115	-	-
	0.41	V-0	4	0	115	-	115	-	-
	0.71	V-0	4	0	115	-	115	-	-
	3.0	V-0	1	0	115	-	115	-	-

CTI: 0 HVTR: 0 D495: 6 IEC BP: -

(a) - One to three digit suffix indicating nominal thickness in mils.
(b) - May have an additional letter suffix indicating color.
(f2) - Subjected to one or more of the following tests: Ultraviolet Light, Water Exposure or Immersion in accordance with UL 746C, where the acceptability for outdoor use is to be determined by UL Inc.

Report Date: 08/19/1991 Underwriters Laboratories Inc ® 357863001
UL 94 small-scale test data does not pertain to building materials, furnishings and related contents. UL94 small-scale test data is intended solely for determining the flammability of plastic materials used in components and parts of end-product devices and appliances, where the acceptability of the combination is determined by ULL.

STATEX™

QMFZ2 Component - Plastics FEBRUARY 25, 2002 E121855

FORMEX, DIV OF ILLINOIS TOOL WORKS INC
1701 W. ARMITAGE COURT ADDISON, IL 60101

Material Designation: STATEX-(a)(b)(f2)
Product Description: Polypropylene (PP), static dissipative treated, furnished as sheets.

Color	Min. Thick. mm	Flame class	HWI	HAI	RTI Elec	RTI Imp	RTI Str	IEC GWIT	IEC GWFI
NC	0.20	VTM-0	5	1	95	-	95	-	-
NC, BK	0.41	V-0	4	3	100	90	100	-	-
ALL	0.75	V-0	3	0	110	105	110	-	-
	2.4	V-0	2	0	110	105	110	-	-
	3.0	V-0	2	0	110	115	120	-	-

CTI: 0 HVTR: 0 D495: 6 IEC BP: -

(a) - One to three digit suffix indicating nominal thickness in mils.
(b) - May have an additional letter suffix indicating color.
(f2) - Subjected to one or more of the following tests: Ultraviolet Light, Water Exposure or Immersion in accordance with UL 746C, where the acceptability for outdoor use is to be determined by UL Inc.

Report Date: 02/09/1989 Underwriters Laboratories Inc ® 357863001
UL 94 small-scale test data does not pertain to building materials, furnishings and related contents. UL94 small-scale test data is intended solely for determining the flammability of plastic materials used in components and parts of end-product devices and appliances, where the acceptability of the combination is determined by ULL.

PHDL2 Component - Plastics FEBRUARY 25, 2002 E121855

FORMEX, DIV OF ILLINOIS TOOL WORKS INC
1701 W. ARMITAGE COURT ADDISON, IL 60101

Material Designation	Color	Thick. (mm)	IEC 707 Flame Class	ISO 1210 Flame Class	ISO 9773 Flame Class
FORMEX GK-(a)(b)	All	0.05	-	-	VF-0
Product Description:		0.41	FVO	FV-O	-
Polypropylene (PP), furnished as sheets		0.71	FVO	FV-O	-
		3.0	FVO	FV-O	-
FORMEX-(a)(b)	NC	0.20	-	-	VF-0
Product Description:	NC,BK	0.41	FVO	FV-O	-
Polypropylene (PP), furnished as sheets	All	0.75	FVO	FV-O	-
STATEX-(a)(b)	NC	0.20	-	-	VF-0
Product Description:	NC,BK	0.41	FVO	FV-O	-
Polypropylene (PP), static dissipative treated, furnished as sheets	All	0.75	FVO	FV-O	-

(a) - One to three digit suffix indicating nominal thickness in mils.
(b) - May have an additional letter suffix indicating color.

Marking: Company name and material designation on container, wrapper or molded on finished part.

See General Information Preceding These Recognitions
For use only in equipment where the acceptability of the combination is determined by Underwriters Laboratories Inc. 357863001

IEC / ISO (PHDL2)

IEC / ISO (PHCA2)

PHCA2 Component - Plastics FEBRUARY 25, 2002 E121855

FORMEX, DIV OF ILLINOIS TOOL WORKS INC
1701 W. ARMITAGE COURT ADDISON, IL 60101

Material Designation	Color	Thick. (mm)	HWI	HAI OS/AS	CTI
FORMEX GK-(a)(b)(@)	All	0.05	8	200/200	@
Product Description:		0.10	9	200/200	@
Polypropylene (PP), furnished as sheets		0.21	7	200/200	@
		0.41	9	162/200	600
		0.71	12	200/200	@
		3.0	91	200/200	@
FORMEX-(a)(b)(@)	NC	0.20	6	113/200	@
Product Description:	NC, BK	0.41	11	23/200	@
Polypropylene (PP), furnished as sheets	All	0.75	21	195/-	@
		2.4	30	200/-	@
		3.0	36	200/-	600
STATEX-(a)(b)(@)	NC	0.20	6	113/200	@
Product Description:		0.41	11	23/200	@
Polypropylene (PP), static dissipative treated, furnished as sheets	All	0.75	21	195/-	@
		2.4	30	200/-	@
		3.0	36	200/-	600

(a) - One to three digit suffix indicating nominal thickness in mils.
(b) - May have an additional letter suffix indicating color.

Marking: Company name and material designation on container, wrapper or molded on finished part.
@ - CTI is a thickness independent test, see rating at thickness tested.

See General Information Preceding These Recognitions
For use only in equipment where the acceptability of the combination is determined by Underwriters Laboratories Inc. 357863001

Note: Check with us for the latest update at www.itwformex.com or at UL, <http://www.ul.com/plastics>

Then "Click here to access UL IQ"
Then register or log in
Select search by Filenumber
Enter E 121855
Submit
Select the grade to view

* Use UL IQ only as any other way does not take you to the yellow card.

FORMEX™ PRODUCT DATA

FLAME RETARDANT POLYPROPYLENE SHEET

ITW Formex®
 1701 W. Armitage Court
 Addison, IL 60101
 630.889.8655 Fax 630.889.8713
 Email sales@itwformex.com
 Web Site www.itwformex.com

TEST METHOD	FORMEX-10	FORMEX-18	FORMEX-20BK	FORMEX-31
Color	Natural	Natural	Black	Natural
Thickness - inch	.010 + .003/ -.0015	.018 + .004/ -.002	.020 ± .002	.031 + .004/ -.000
Thickness - millimeter	.25 + .08/ -.04	.46 + .10/ -.05	.51 ± .05	.79 + .10/ -.00
MECHANICAL PROPERTIES				
Tensile Yield - psi	ASTM D-882			
Machine Direction	4800	4800	4800	4800
Transverse Direction	3600	3600	3600	3600
PHYSICAL PROPERTIES				
Density - gm/cc	ASTM D-792	0.988	0.988	0.988
Flammability	UL 94	VTM-0	V-0	V-0
Oxygen Index	ASTM D-2863	28	28	28
Water Absorption - % change in weight	ASTM D-570	0.01%	0.01%	0.01%
Heat Deflection Temperature at 66 psi	ASTM D-648	106°C/223°F	106°C/223°F	106°C/223°F
Relative Thermal Index	UL 746B			
Electrical		95°C/203°F	100°C/212°F	110°C/230°F
Mechanical Without Impact		95°C/203°F	100°C/212°F	110°C/230°F
Surface Energy - dynes/cm (as produced)	ASTM D-2578	≥ 50	≥ 50	≥ 50
ELECTRICAL PROPERTIES				
Dielectric Breakdown - volts	ASTM D-149	18,000	30,960	28,400
Dielectric Strength - volts/mil	ASTM D-149	1800	1720	1420
Volume Resistivity - ohm-cm	ASTM D-257	146 x 10 ¹⁵	146 x 10 ¹⁵	146 x 10 ¹⁵
Dielectric Constant	ASTM D-150	2.30	2.30	2.30
Dissipation Factor	ASTM D-150	0.0009	0.0009	0.0009
High Current Arc Ignition - arcs to ignite	UL 746A	113	23	23
High Voltage Arc Tracking - in/min	UL 746A	0.0	0.0	0.0
Hot Wire Ignition - seconds	UL 746A	6	11	11
Comparative Tracking Index - volts	ASTM D-3638	600	600	600
PACKAGING INFORMATION				
Standard Configuration		Roll	Roll & Sheet	Roll
Core ID - inches		6	6	6
Roll OD - inches (approximate)		18	18	18
Roll Width - inches		24	24 & 25	24
Roll Weight - lbs (approximate)		225	200	225
Length/Roll - feet		2000	1000	1000
Area/Roll - square feet		4000	2000 & 2083	2000
Sheet Sizes - inches		-	24 x 48	-

THICKER MATERIALS ALSO AVAILABLE

Notice: The above information is believed to be accurate and reliable. ITW assumes no responsibility for end use applications and no performance warranty is expressed or implied.



File Number E121855 - Yellow Card available on request

MIL Handbook 454 - Fungus-inert-Group I

For a complete listing of Formex products, contact your Formex/Statex sales representative.

FORMEX™ PRODUCT DATA

FLAME RETARDANT POLYPROPYLENE SHEET

ITW Formex® 1701 W. Armitage Court
 Addison, IL 60101
 630.889.8655 Fax 630.889.8713
 Email sales@itwformex.com
 Web Site www.itwformex.com

	TEST METHOD	FORMEX-94BK	FORMEX-125BK
Color		Black	Black
Thickness - inch		.094 ±.004	.125 ±.007
Thickness - millimeter		2.38 ± .10	3.18 ± .18
MECHANICAL PROPERTIES			
Tensile Yield - psi	ASTM D-882		
Machine Direction		4800	4800
Transverse Direction		3600	3600
PHYSICAL PROPERTIES			
Density - gm/cc	ASTM D-792	0.988	0.988
Flammability	UL 94	V-0	V-0
Oxygen Index	ASTM D-2863	28	28
Water Absorption - % change in weight	ASTM D-570	0.01%	0.01%
Heat Deflection Temperature at 66 psi	ASTM D-648	106°C/223°F	106°C/223°F
Relative Thermal Index	UL 746B		
Electrical		110°C/230°F	110°C/230°F
Mechanical Without Impact		110°C/230°F	120°C/248°F
Surface Energy - dynes/cm (as produced)	ASTM D-2578	≥ 50	≥ 50
ELECTRICAL PROPERTIES			
Dielectric Breakdown - volts	ASTM D-149	56,400	62,500
Dielectric Strength - volts/mil	ASTM D-149	600	500
Volume Resistivity - ohm-cm	ASTM D-257	146 x 10 ¹⁵	146 x 10 ¹⁵
Dielectric Constant	ASTM D-150	2.30	2.30
Dissipation Factor	ASTM D-150	0.0009	0.0009
High Current Arc Ignition - arcs to ignite	UL 746A	200	200
High Voltage Arc Tracking - in/min	UL 746A	0.0	0.0
Hot Wire Ignition - seconds	UL 746A	30	36
Comparative Tracking Index - volts	ASTM D-3638	600	600
PACKAGING INFORMATION			
Standard Configuration		Sheet	Sheet
Core ID - inches		-	-
Roll OD - inches (approximate)		-	-
Roll Width - inches		-	-
Roll Weight - lbs (approximate)		-	-
Length/Roll - feet		-	-
Area/Roll - square feet		-	-
Sheet Sizes - inches		24 x 48	24 x 48

Notice: The above information is believed to be accurate and reliable. ITW assumes no responsibility for end use applications and no performance warranty is expressed or implied.



File Number E121855 - Yellow Card available on request

MIL Handbook 454 - Fungus-inert-Group I

For a complete listing of Formex products, contact your Formex/Statex sales representative.

FORMEX™ GK PRODUCT DATA

FLAME RETARDANT POLYPROPYLENE SHEET

ITW Formex® 1701 W. Armitage Court
 Addison, IL 60101
 630.889.8655 Fax 630.889.8713
 Email sales@itwformex.com
 Web Site www.itwformex.com

	TEST METHOD	FORMEX GK-5BK	FORMEX GK-10	FORMEX GK-17	FORMEX GK-30	FORMEX GK-40	FORMEX GK-62
Color		Black	Natural & Black	Natural & Black	Natural & Black	Natural & Black	Natural & Black
Thickness - inch		.005 ± .001	.010 + .003/ -.0015	.017 + .003/ -.001	.030 ± .002	.040 ± .002	.062 ± .004
Thickness - millimeter		.127 ± .025	.25 + .08/ -.04	.43 + .08/ -.03	.76 ± .05	1.02 ± .05	1.57 ± .10
MECHANICAL PROPERTIES							
Tensile Yield - psi	ASTM D-882						
Machine Direction		4400	4400	4400	4400	4400	4400
Transverse Direction		3200	3200	3200	3200	3200	3200
PHYSICAL PROPERTIES							
Density - gm/cc	ASTM D-792	1.035	1.035	1.035	1.035	1.035	1.035
Flammability	UL 94	VTM-0	VTM-0	V-0	V-0	V-0	V-0
Oxygen Index	ASTM D-2863	29	29	29	29	29	29
Water Absorption - % change in weight	ASTM D-570	0.06%	0.06%	0.06%	0.06%	0.06%	0.06%
Heat Deflection Temperature at 66 psi	ASTM D-648	121°C/250°F	121°C/250°F	121°C/250°F	121°C/250°F	121°C/250°F	121°C/250°F
Relative Thermal Index	UL 746B						
Electrical		115°C/239°F	115°C/239°F	115°C/239°F	115°C/239°F	115°C/239°F	115°C/239°F
Mechanical Without Impact		115°C/239°F	115°C/239°F	115°C/239°F	115°C/239°F	115°C/239°F	115°C/239°F
Surface Energy - dynes/cm (as produced)	ASTM D-2578	≥ 50 outside only**	≥ 50	≥ 50	≥ 50	≥ 50	≥ 50
ELECTRICAL PROPERTIES							
Dielectric Breakdown - volts	ASTM D-149	13,125	22,000	24,820	32,400	37,800	45,260
Dielectric Strength - volts/mil	ASTM D-149	2625	2200	1460	1080	945	730
Volume Resistivity - ohm-cm	ASTM D-257	3.97x 10 ¹⁵	3.97x 10 ¹⁵	3.97x 10 ¹⁵	3.97x 10 ¹⁵	3.97x 10 ¹⁵	3.97x 10 ¹⁵
Dielectric Constant	ASTM D-150	2.30	2.30	2.30	2.30	2.30	2.30
Dissipation Factor	ASTM D-150	0.0019	0.0019	0.0019	0.0019	0.0019	0.0019
High Current Arc Ignition - arcs to ignite	UL 746A	200	200	162	200	200	200
High Voltage Arc Tracking - in/min	UL 746A	0.0	0.0	0.0	0.0	0.0	0.0
Hot Wire Ignition - seconds	UL 746A	9	7	9	12	12	12
Comparative Tracking Index - volts	ASTM D-3638	600	600	600	600	600	600
PACKAGING INFORMATION							
Standard Configuration		Roll	Roll	Roll & Sheet	Roll & Sheet	Sheet	Sheet
Core ID - inches		6	6	6	6	-	-
Roll OD - inches (approximate)		18	18	18	18	-	-
Roll Width - inches		24	24	24 & 25	24	-	-
Roll Weight - lbs (approximate)		205	225	200	200	-	-
Length/Roll - feet		4000	2000	1000	600	-	-
Area/Roll - square feet		8000	4000	2000 & 2083	1200	-	-
Sheet Sizes - inches		-	-	24 x 48	24 x 48, 48 x 96*	24 x 48, 48 x 96*	24 x 48, 48 x 96*

* Black only

** Treated one side only

Notice: The above information is believed to be accurate and reliable. ITW assumes no responsibility for end use applications and no performance warranty is expressed or implied.

FMXGK 5/62-D



File Number E121855 - Yellow Card available on request

MIL Handbook 454 - Fungus-Inert-Group I

For a complete listing of Formex products, contact your Formex/Statex sales representative.

STATEX™ PRODUCT DATA

STATIC DISSIPATIVE FLAME RETARDANT POLYPROPYLENE SHEET

ITW Formex® 1701 W. Armitage Court
Addison, IL 60101
630.889.8655 Fax 630.889.8713
Email sales@itwformex.com
Web Site www.itwformex.com

	TEST METHOD	STATEX-10	STATEX-18	STATEX-31
Color		Natural*	Natural*	Natural*
Thickness - inch		.010 + .003/ -.0015	.018 + .004/ -.002	.031 + .004/ -.000
Thickness - millimeter		.25 + .08/ -.04	.46 + .10/ -.05	.79 + .10/ -.00
MECHANICAL PROPERTIES				
Tensile Yield - psi	ASTM D-882			
Machine Direction		4800	4800	4800
Transverse Direction		3600	3600	3600
PHYSICAL PROPERTIES				
Density - gm/cc	ASTM D-792	0.988	0.988	0.988
Flammability	UL 94	VTM-0	V-0	V-0
Oxygen Index	ASTM D-2863	28	28	28
Water Absorption - % change in weight	ASTM D-570	0.01%	0.01%	0.01%
Heat Deflection Temperature at 66 psi	ASTM D-648	106°C/223°F	106°C/223°F	106°C/223°F
Relative Thermal Index	UL 746B			
Electrical		95°C/203°F	100°C/212°F	110°C/230°F
Mechanical Without Impact		95°C/203°F	100°C/212°F	110°C/230°F
ELECTRICAL PROPERTIES				
Static Decay - seconds (Federal Test Method 101C)	ASTM D-257	< 2	< 2	< 2
Surface Resistivity - ohms/square	ASTM D-257	10 ⁹ to 10 ¹¹	10 ⁹ to 10 ¹¹	10 ⁹ to 10 ¹¹
Dielectric Breakdown - volts	ASTM D-149	17,500	27,540	37,200
Dielectric Strength - volts/mil	ASTM D-149	1750	1530	1200
Volume Resistivity - ohm-cm	ASTM D-257	146 x 10 ¹⁵	146 x 10 ¹⁵	146 x 10 ¹⁵
Dielectric Constant	ASTM D-150	2.3	2.3	2.3
Dissipation Factor	ASTM D-150	0.0009	0.0009	0.0009
High Current Arc Ignition - arcs to ignite	UL 746A	113	23	195
High Voltage Arc Tracking - in/min	UL 746A	0.0	0.0	0.0
Hot Wire Ignition - seconds	UL 746A	6	11	21
Comparative Tracking Index - volts	ASTM D-3638	600	600	600

STATEX MATERIAL TREATED ON BOTH SIDES ALSO AVAILABLE

* Product is line-marked on treated side with carbonless black ink.

Notice: The above information is believed to be accurate and reliable. ITW assumes no responsibility for end use applications and no performance warranty is expressed or implied.



File Number E121855 - Yellow Card available on request

MIL Handbook 454 - Fungus-inert-Group I

For a complete listing of
Statex products, contact your
Formex/Statex sales representative.

DETERMINING THE OUTSIDE SURFACE

All folds will have the score ("v" groove) on the outside, placing the hinge to the inside of the container.

FORMING THE SIDE WALLS OF THE CONTAINER

Push the two tabs into their respective slits closing the side walls.

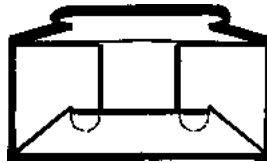
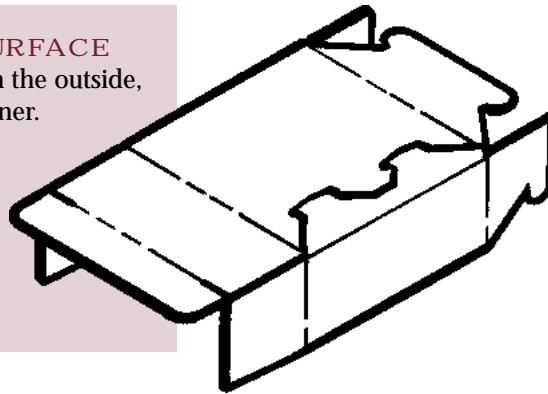
**BOTTOM ASSEMBLY**

1. Fold bottom flap up and side flaps out.
2. Fold side flaps inward, making sure tabs are caught securely behind notched section in bottom flap.
3. Fold top over side flaps securing its tabs between side and bottom flaps.

CLOSURE

Fold the side flaps in and close in conventional manner.

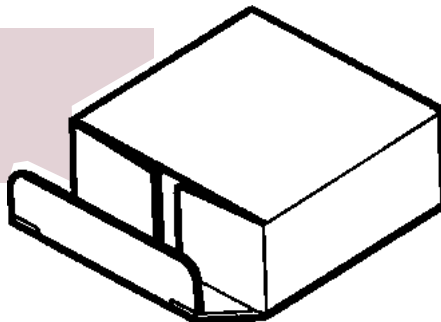

The data listed herein fall within the normal range of product properties but they should not be used to establish specification limits nor used alone as the basis of design. ITW assumes no obligation or liability

for any advice furnished by it or the results obtained with respect to these products. All such advice is provided gratis and Buyer assumes sole responsibility for results obtained in reliance thereon.



1701 W. Armitage Court
Addison, IL 60101
630.889.8655 Fax 630.889.8713
Email sales@itwformex.com
Web Site www.itwformex.com

FMX DG 3/02
Printed in U.S.A.
© 2002 ITW Formex